

An overview of research areas in hybrid control

John Lygeros

Department of Electrical and Computer Engineering

University of Patras

Rio, Patras, GR-26500

Greece

lygeros@ee.upatras.gr

Hybrid dynamics [Johansson et.al.]

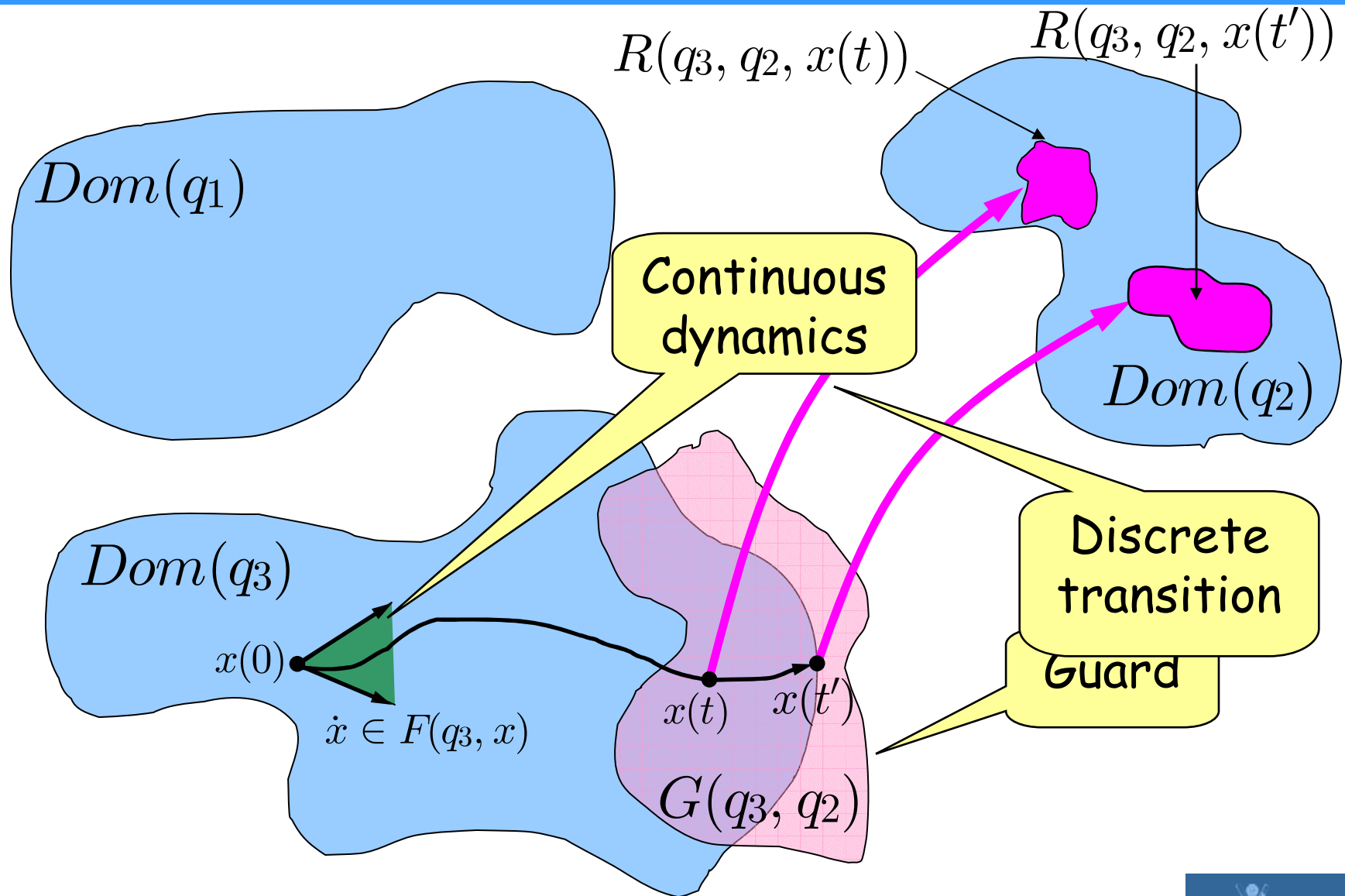

Uncertainty



- Solutions defined “**declaratively**”
- Many “degrees of freedom”
 - Multiple continuous flow directions $\dot{x} \in F(q, x)$
 - Multiple discrete state destinations
$$G(q, q') \cap G(q, q'') \neq \emptyset$$
 - Multiple continuous state destinations
$$x' \in R(q, q', x)$$
 - Choice between flowing and jumping
$$x \in Dom(q) \cap G(q, q')$$

Hybrid control

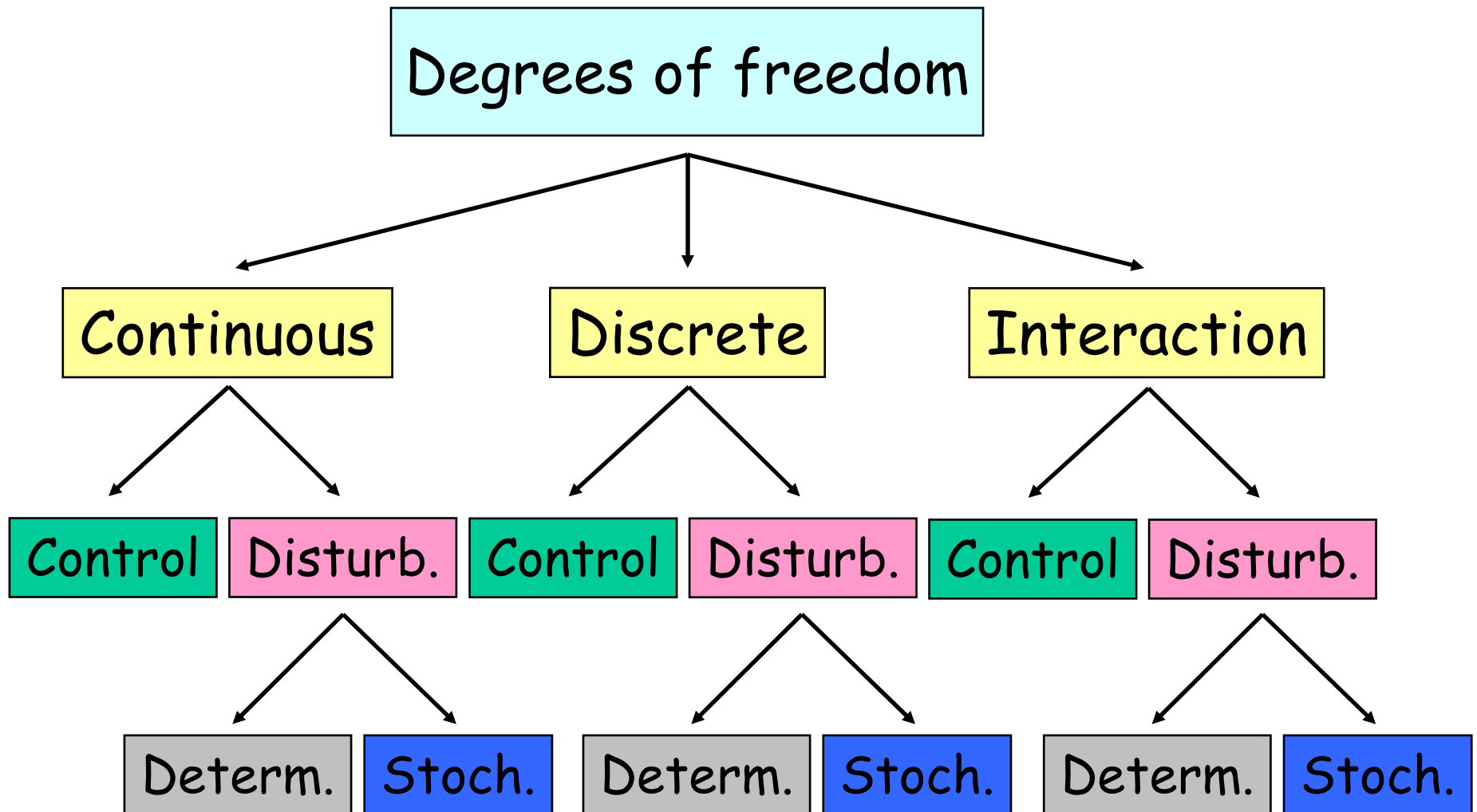

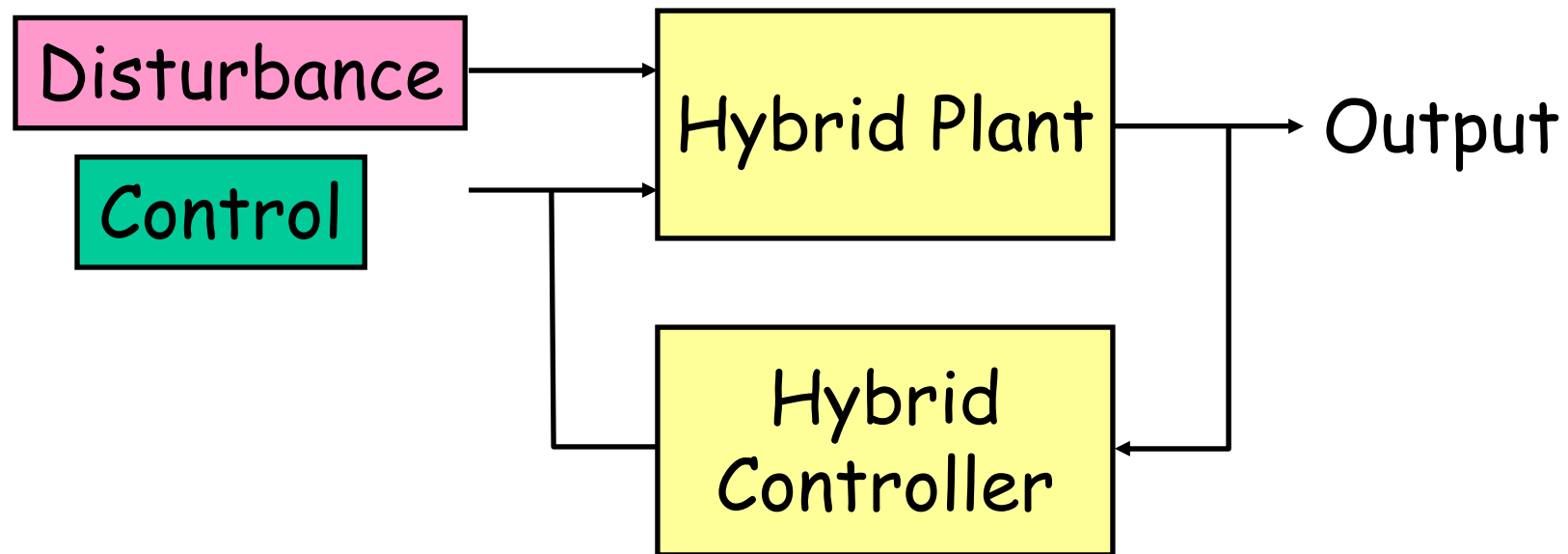

Information and strategies



- Information structures
 - Full state measurement
 - Output feedback
- Strategies
 - Open loop
 - Feedback
 - Non-anticipative
 - Markov policies, etc.

Classification and literature review



- Uncertainty
 - Deterministic
 - Non-deterministic
 - Stochastic
- Objective
 - Stabilization
 - Optimal control
 - Language specifications

More extensive treatment in "**An overview of hybrid systems control**", in *Handbook of Networked and Embedded Control Systems*, D. Hristu-Varsakelis and W.S. Levine eds., pp 519-538, 2005

Stabilization



- Invariant set W

$$(q_0(\tau_0), x_0(\tau_0)) \in W \Rightarrow (q_i(t), x_i(t)) \in W \quad \forall i, t$$

- E.g. equilibrium
- Design controller such that

$$d[(q_0(\tau_0), x_0(\tau_0)), W] < \delta \Rightarrow d[(q_i(t), x_i(t)), W] < \epsilon \quad \forall i, t$$

and/or

$$d[(q_i(t), x_i(t)), W] \rightarrow 0 \quad \text{as } i, t \rightarrow \infty$$

Disturbances et.al.



- Non-deterministic
 - Practical stabilization
- Stochastic
 - Invariant measure
 - Almost sure stability
 - Moment stability
 - ...
- Tools:
 - Switched linear systems
 - Mathematical programming, LMI
- In applications, e.g.
 - Stability of networked control systems

Optimal control



- Introduce cost

- Continuous motion

$$\sum_i \int_{\tau_i}^{\tau'_i} l(q_i(t), x_i(t), u_i(t)) dt$$

- Discrete transitions

$$\sum_i g(q_i(\tau'_i), x_i(\tau'_i), q_{i+1}(\tau_{i+1}), x_{i+1}(\tau_{i+1}), u_i(\tau'_i), v_i(\tau'_i))$$

- Design controller to minimize

- Dynamic programming
- Maximum principle
- Model predictive control

Disturbances et.al.



- Non-deterministic -> hybrid games
- Stochastic
 - Dynamic programming
- Numerical tools
 - Maximum principle [Caines et.al.]
 - Dynamic programming [Tomlin et.al.]
 - MPC [Morari, Bemporad et.al.]
- In applications:
 - Power systems

Language specifications

- Defined as an acceptable set of hybrid trajectories
- E.g.
 - Safety: always remain in a good part of the state space
 - Liveness: eventually reach a good part of the state space
 - Combinations thereof
- Design controller such that closed loop solutions are in acceptable set

Results and applications



- Finite state systems -> bisimulation
 - Timed automata, multi-rate automata
 - "Linear" hybrid automata
 - Linear systems
- General hybrid systems
- Tools
 - Symbolic
 - Numerical, barrier functions
- In applications: industrial processes
 - Safe controller design
 - Large transitions (e.g. start-up)

Concluding remarks



- Hybrid control very active and diverse
- Open problems in all the above areas
- Challenges:
 - Dynamic/output feedback <- Hybrid observers
 - Hybrid games -> Robust control
 - Stochastic hybrid systems, especially language specifications
 - Tools/approximations for realistic size systems
- Applications!

Structure of the tutorial



~~Overview of research in hybrid control~~

Recent developments in applications

Power management

Industrial processes

Automotive

Communication networks