



On Hybrid Control Problems in Communication Systems

Karl Henrik Johansson

School of Electrical Engineering
Royal Institute of Technology
Stockholm, Sweden

Fortunato Santucci

Center of Excellence DEWS
University of L'Aquila
L'Aquila, Italy

Based on joint work with partners in HYCON WP4d on Networked Control:
UCL, INRIA, UPAT, UAQ, UNIPI, UNISI, PARADES, KTH, ULIN, LTH, CNR



Wireless control systems everywhere

M2M Device Population Forecast 2010

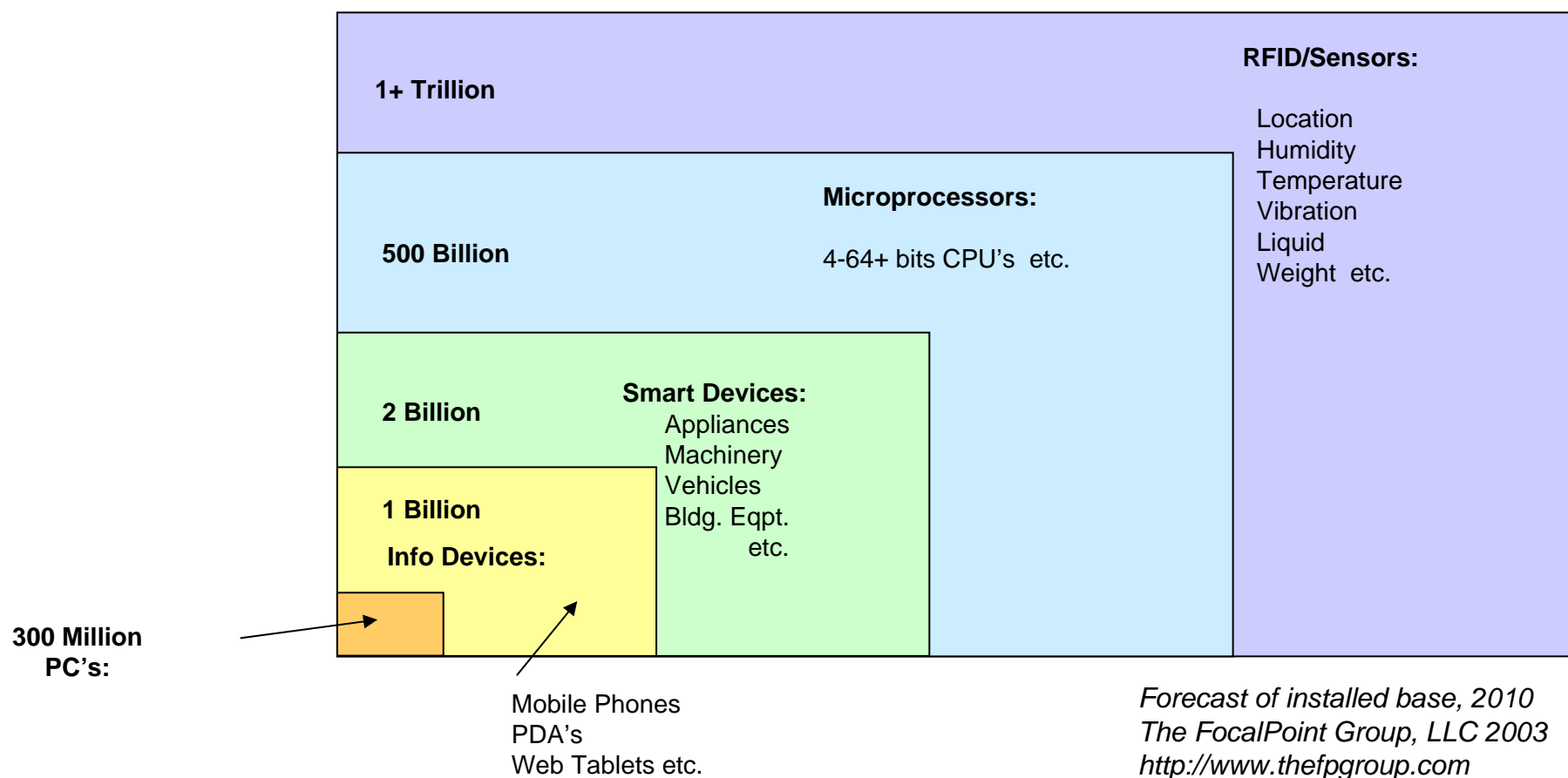



Wireless manufacturing

- Wireless technology offers large potential in manufacturing and automation in terms of added flexibility and mobility
 - May drastically decrease cost in
 - planning and engineering
 - installation and commissioning
 - operation and maintenance
 - But challenges in safety, reliability and security
-
- The diagram illustrates a wireless manufacturing network. It starts with an 'input' arrow pointing to a worker with a handheld device. This device is connected via 'ZigBee' to a 'processes' station. From there, a 'multihop' connection leads to a 'maintenance' station. Another 'multihop' connection leads to a 'logistics' station, which is connected to a yellow forklift. The forklift is connected via 'UMTS' to a 'manufacturing' station. The manufacturing station is connected via 'bluetooth' to another worker. Finally, the manufacturing station is connected via 'WLAN' to an 'output' arrow. The diagram also shows a lightning bolt symbol near the manufacturing station, possibly representing power or a specific wireless technology.
- HYCON WP4d focuses on two important problems in wireless manufacturing:
 - How to increase mobility and collaboration in a rigorous way
 - How to achieve suitable control performance despite resource constraints
 - HYCON WP4d is applying hybrid control techniques in two case studies:
 - Hybrid control of multi-robot systems over distributed wireless communication
 - Distributed and hybrid control of resources in wireless networks for control applications



Case study a: Hybrid control of multi-robot systems over wireless communication

Explore hybrid systems tools to model and analyze collaborative behaviour of multi-agent control systems to gain insight on performance limitations induced by the need of exchanging information across unreliable wireless links

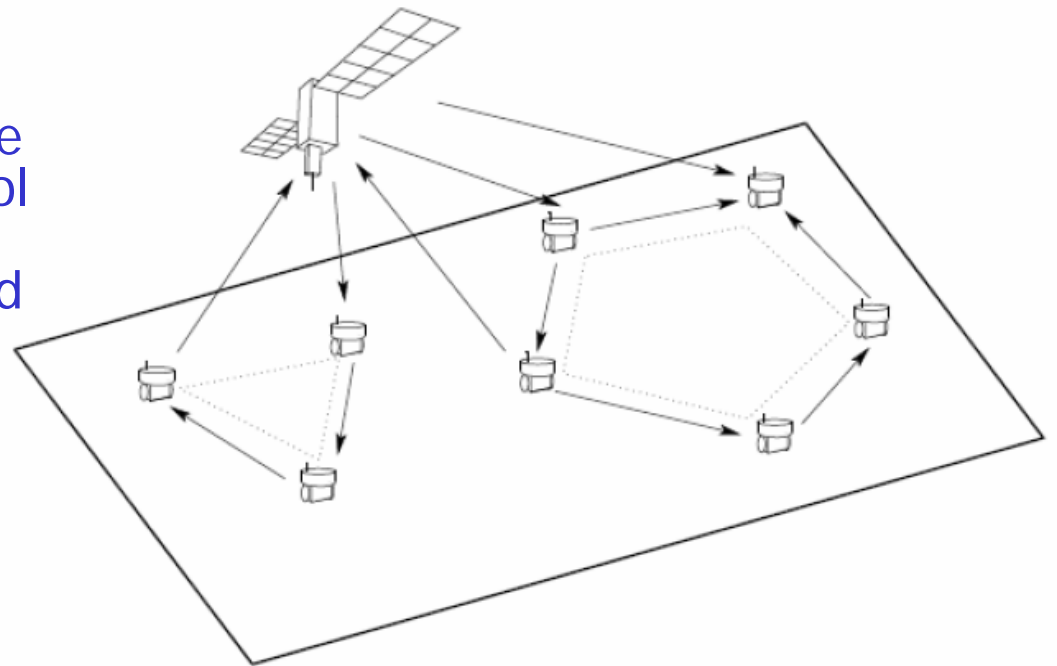

Hybrid dynamics because, e.g.,

- hybrid collaborative dynamics due to varying communication topology
- control law switches between discrete formations
- symbolic control information communicated between robots



Case study b: Distributed and hybrid control of resources in control over wireless networks

Develop hybrid models that allow joint consideration of control application and underlying wireless network to adapt to variations in application demands and available resources

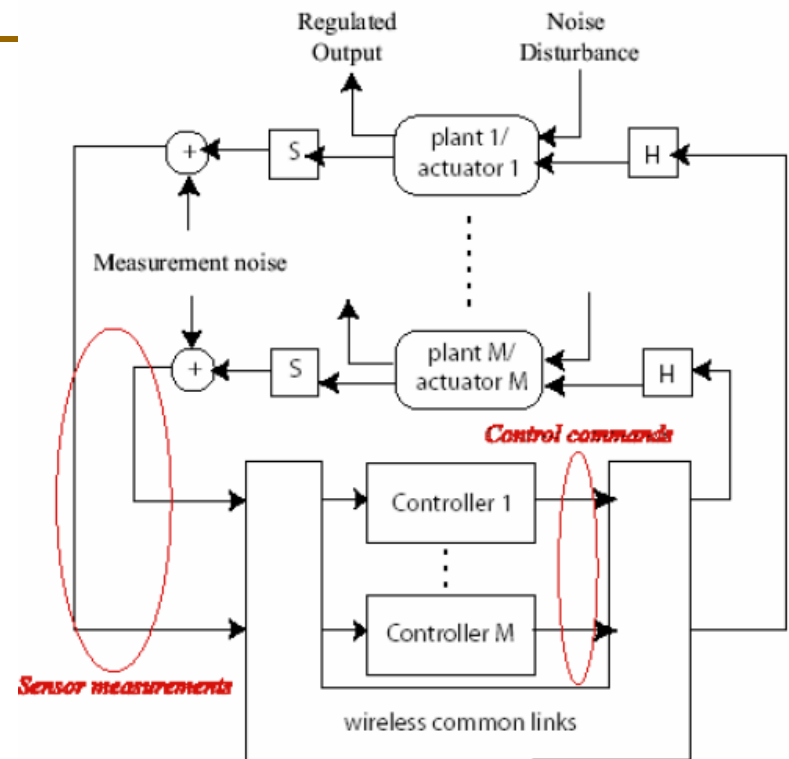

Hybrid dynamics because, e.g.,

- network configuration determined by outage events in wireless links
- single link represented by finite set of channel capacities
- control applications use a time-varying set of sensors and actuators



Control over heterogeneous networks

- The integration of wireless and wired technology for control and estimation applications in manufacturing presents many open problems, e.g., on undesirable cross-layer interactions

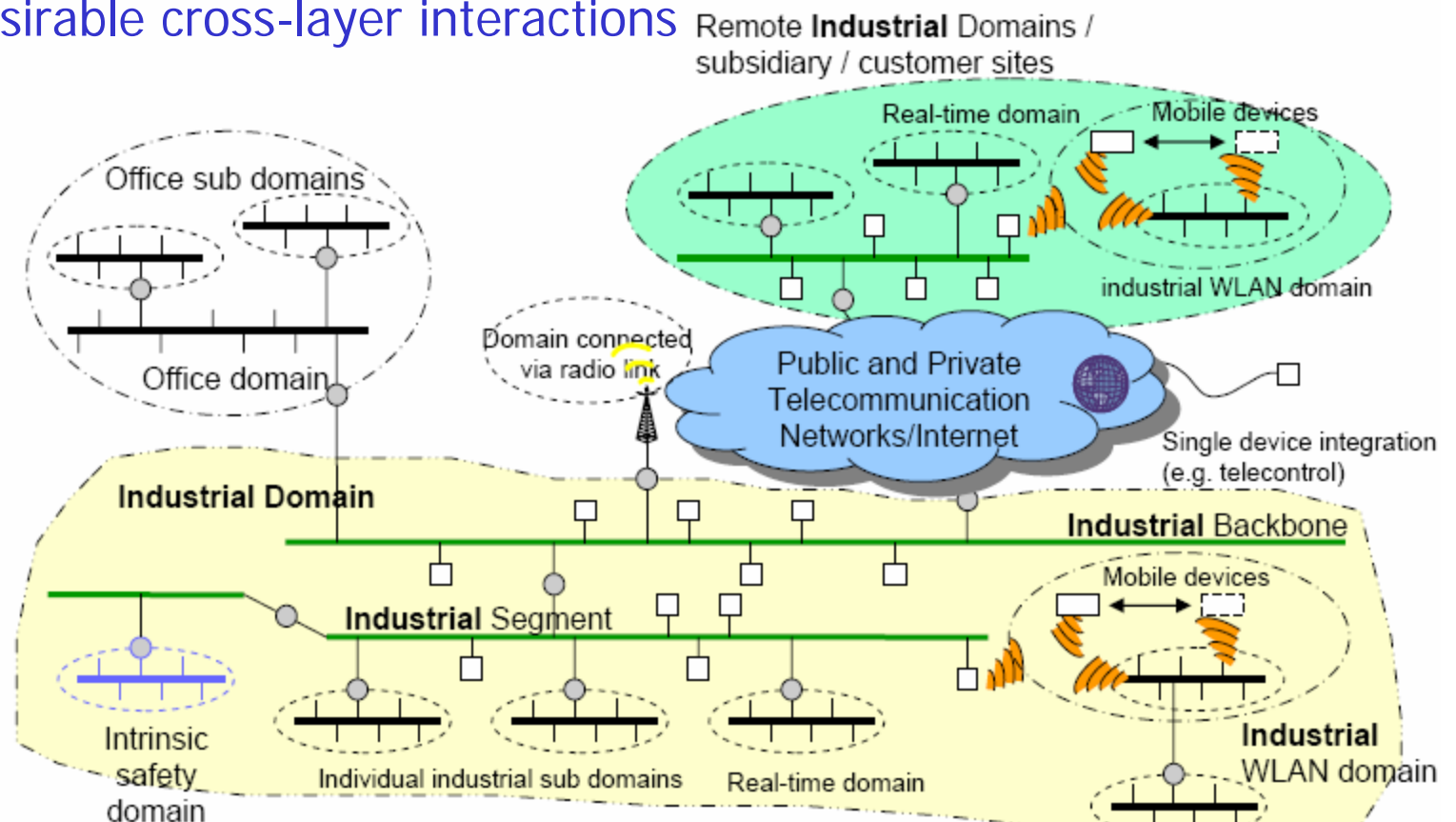

[Klostermeyer, 2005 (Siemens)]



Cascaded control loops enable layered design

- Several cascaded control loops separate communication layers
 - Inner and outer power controls
 - Link-layer retransmission
 - Forward error correction

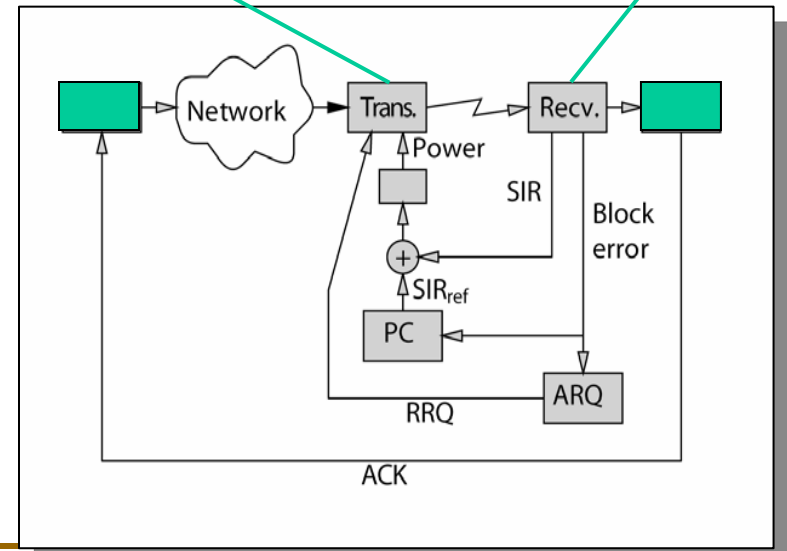
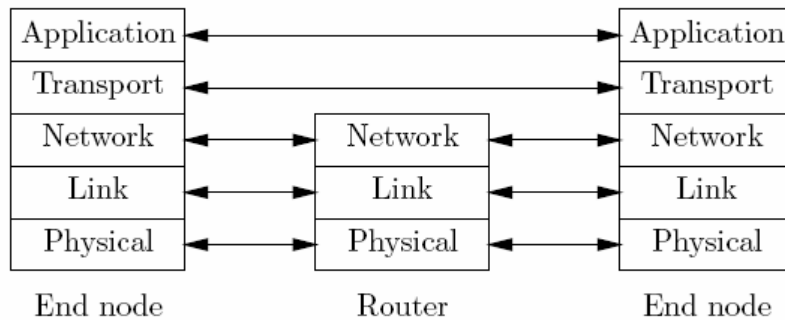
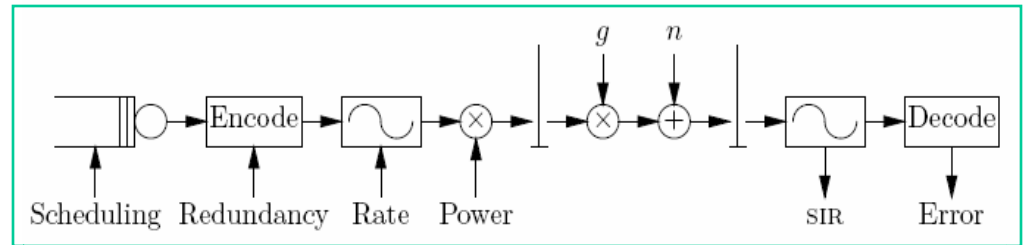

[Möller and J, 2003]



Hybrid model of end-to-end communication over wireless networks

- Cross-layer interaction between radio link and transport protocol
- Modelled through stochastic hybrid system

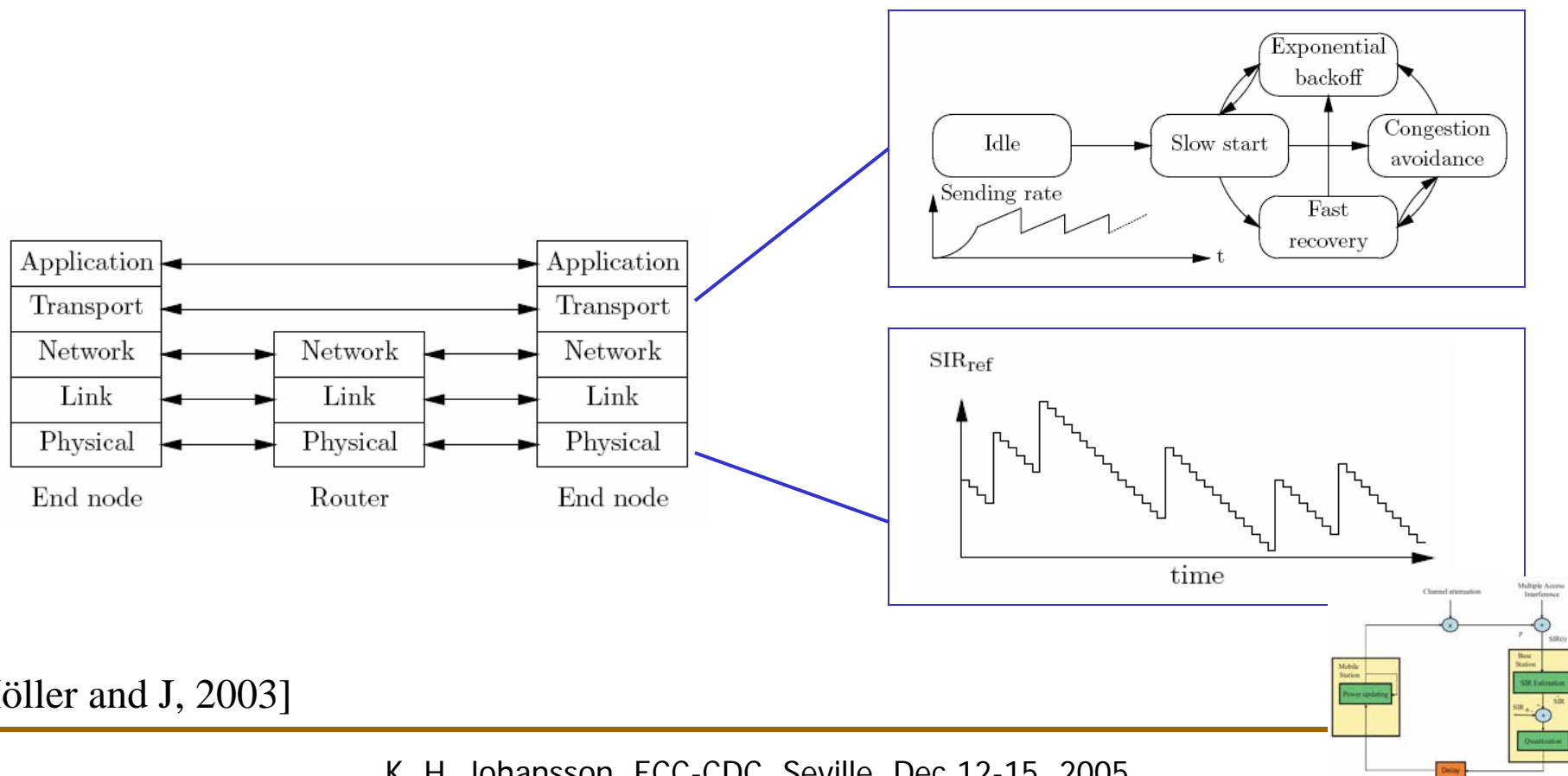

[Möller and J, 2003]



Wireless link characteristic reduces achievable end-to-end bandwidth

$$P_{TO} = P(RTT > E\{RTT\} + 4\sigma\{RTT\})$$

- End-to-end bandwidth reduction due to small changes in delay distribution, which triggers TCP slow starts

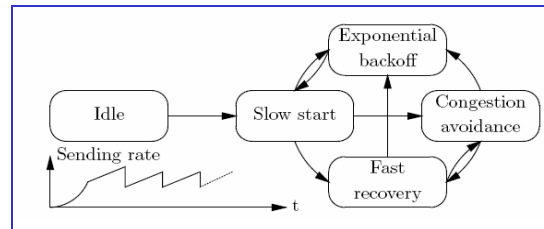

- Can be compensated through
 - split connection
 - link-layer improvements
 - end-to-end modifications

- See [ThB14.1, Möller et al.] for details on solution developed with Ericsson AB

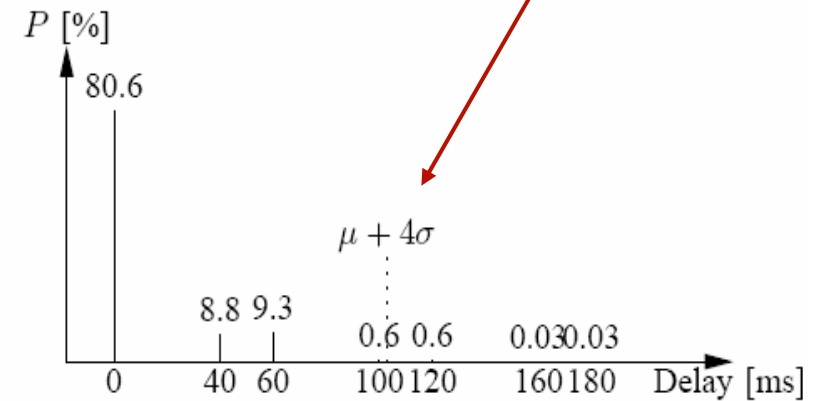

Fig. 6. Original delay distribution

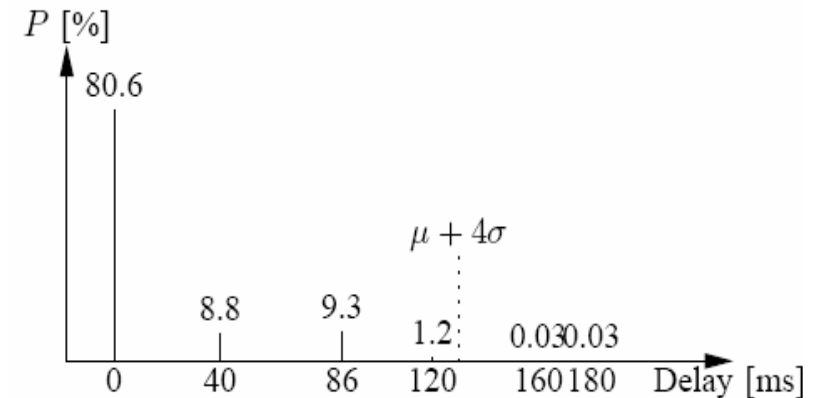

Fig. 7. Optimized delay distribution



Conclusions

- Wireless manufacturing is an emerging area that poses several open problems in networked control related to safety and reliability
- Hybrid system tools might be suitable to tackle some of the problems, due to the hybrid nature of these resource-constrained control systems
- Hybrid model that captures several communication layers
- Shows how cross-layer interactions may deteriorate achievable end-to-end performance in communication systems

www.ist-hycon.org

